

# LOCKS



# SERRATURE LOCKS

L'ESCLUSIVA COLLEZIONE DI SERRATURE  
MAGNETICHE E MECCANICHE VERUM ITALY.  
REALIZZATE IN ITALIA E TESTATE SECONDO LA  
NORMA UNI EN 12209.

THE EXCLUSIVE COLLECTION OF VERUM  
ITALY MAGNETIC AND MECHANICAL LOCKS.  
MADE IN ITALY AND TESTED ACCORDING  
TO UNI EN 12209.



**SERRATURE  
LOCKS**

SERRATURE MAGNETICHE / MAGNETIC LOCKS  
COD. 180

SERRATURE MECCANICHE / MECHANICAL LOCKS  
COD. 183

FORO CHIAVE /  
KEY HOLE

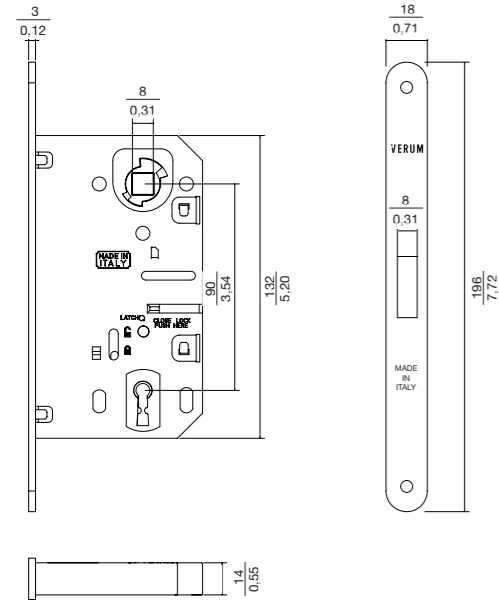

FORO CILINDRO /  
CYLINDER HOLE

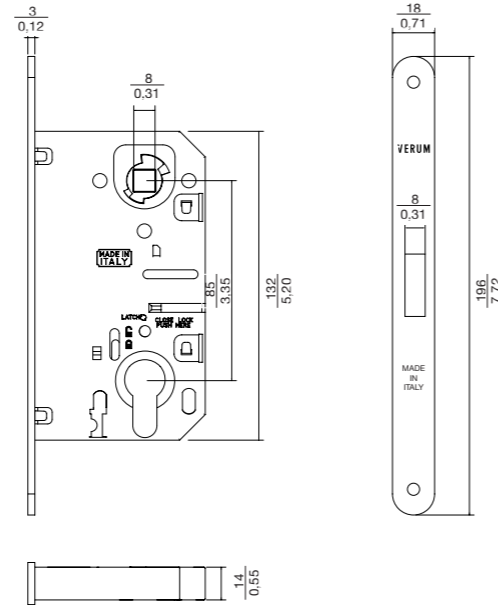

FORO NOTTOLINO /  
PRIVACY SET HOLE

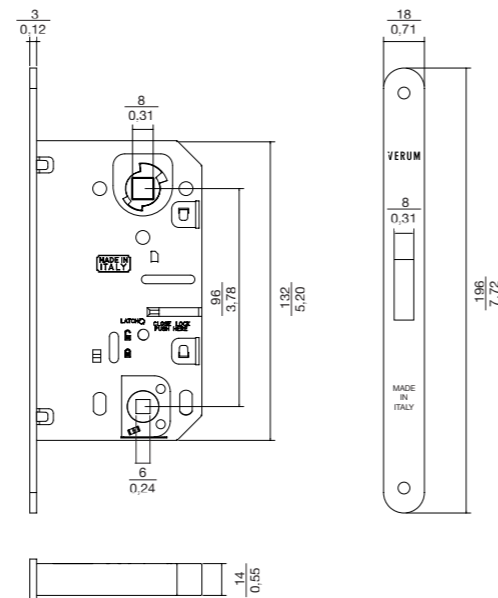

COD. 14 CROMO SATINATO SATIN CHROME  
COD. 08 ARGENTO VERNICIATO SILVER PAINTED  
COD. 39 CROMO LUCIDO POLISHED CHROME  
COD. 49 BIANCO VERNICIATO WHITE PAINTED

COD. 18 NERO VERNICIATO BLACK PAINTED  
COD. 21 BRONZO YESTER YESTER BRONZE  
COD. 37 OTTONATO LUCIDO BRASS PLATED

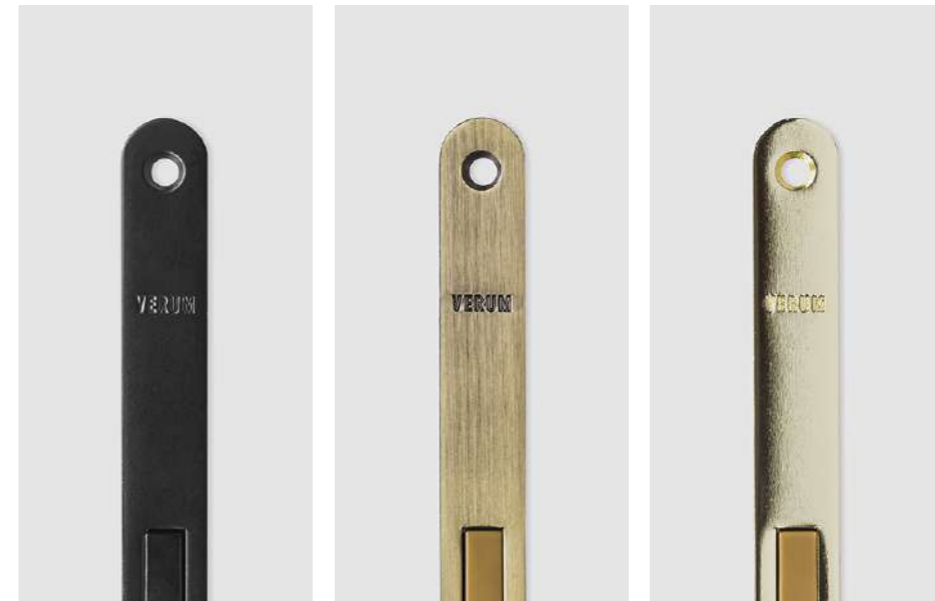

MM  
INCH

**INCONTRI**  
**STRIKING PLATES**

MM	22	15
INCH	0,87	0,59

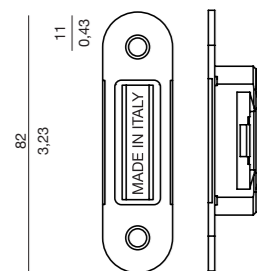

INCONTRO CON PIASTRINA PER SERRATURA MAGNETICA /  
STRIKING PLATE WITH PLATELET FOR MAGNETIC LOCK  
COD. 181003

INCONTRO CON PIASTRINA PER SERRATURA MECCANICA /  
STRIKING PLATE WITH PLATELET FOR MECHANICAL LOCK  
COD. 184004

**FINITURE / FINISHES**

- COD. 14 CROMO SATINATO / SATIN CHROME
- COD. 39 CROMO LUCIDO / POLISHED CHROME
- COD. 08 ARGENTO VERNICIATO / SILVER PAINTED
- COD. 49 BIANCO VERNICIATO / WHITE PAINTED
- COD. 18 NERO VERNICIATO / BLACK PAINTED
- COD. 21 BRONZO YESTER / YESTER BRONZE
- COD. 37 OTTONATO LUCIDO / BRASS PLATED

**MATERIALE / MATERIAL**

METALLO E ABS / METAL AND ABS

7,6	6,1	14,5
0,26	0,24	0,57

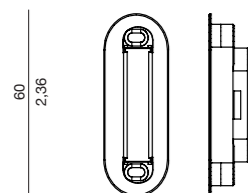

INCONTRO PER SERRATURA MAGNETICA LARGHEZZA 22 MM - 0,87 INCH /  
STRIKING PLATE FOR MAGNETIC LOCK WIDTH 22 MM - 0,87 INCH  
COD. 181007

INCONTRO PER SERRATURA MECCANICA LARGHEZZA 22 MM - 0,87 INCH /  
STRIKING PLATE FOR MECHANICAL LOCK WIDTH 22 MM - 0,87 INCH  
COD. 184006

DISPONIBILE ANCHE / ALSO AVAILABLE:

INCONTRO PER SERRATURA MAGNETICA CON COVER COPRIVITE LARGHEZZA 22 MM - 0,87 INCH /  
STRIKING PLATE FOR MAGNETIC LOCK WITH SCREW COVER WIDTH 22 MM - 0,87 INCH  
COD. 181007\_CO

INCONTRO PER SERRATURA MECCANICA CON COVER COPRIVITE LARGHEZZA 22 MM - 0,87 INCH /  
STRIKING PLATE FOR MECHANICAL LOCK WITH SCREW COVER WIDTH 22 MM - 0,87 INCH  
COD. 184006\_CO

**FINITURE / FINISHES**

- COD. 14 GRIGIO / GREY
- COD. 18 NERO / BLACK
- COD. 49 BIANCO / WHITE
- COD. 24 HAVANA / HAVANA

**MATERIALE / MATERIAL**

ABS / ABS

9,1	7,6	14,5
0,36	0,26	0,57

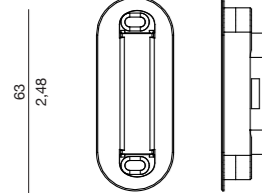

INCONTRO PER SERRATURA MAGNETICA LARGHEZZA 25 MM - 0,98 INCH /  
STRIKING PLATE FOR MAGNETIC LOCK WIDTH 25 MM - 0,98 INCH  
COD. 181008

INCONTRO PER SERRATURA MECCANICA LARGHEZZA 25 MM - 0,98 INCH /  
STRIKING PLATE FOR MECHANICAL LOCK WIDTH 25 MM - 0,98 INCH  
COD. 184007

DISPONIBILE ANCHE / ALSO AVAILABLE:

INCONTRO PER SERRATURA MAGNETICA CON COVER COPRIVITE LARGHEZZA 25 MM - 0,98 INCH /  
STRIKING PLATE FOR MAGNETIC LOCK WITH SCREW COVER WIDTH 25 MM - 0,98 INCH  
COD. 181008\_CO

INCONTRO PER SERRATURA MECCANICA CON COVER COPRIVITE LARGHEZZA 25 MM - 0,98 INCH /  
STRIKING PLATE FOR MECHANICAL LOCK WITH SCREW COVER WIDTH 25 MM - 0,98 INCH  
COD. 184007\_CO

**FINITURE / FINISHES**

- COD. 14 GRIGIO / GREY
- COD. 18 NERO / BLACK
- COD. 49 BIANCO / WHITE
- COD. 24 HAVANA / HAVANA

**MATERIALE / MATERIAL**

ABS / ABS



COD. 21 BRONZO YESTER  
YESTER BRONZE



COD. 18 NERO VERNICIATO  
BLACK PAINTED



COD. 08 ARGENTO VERNICIATO  
SILVER PAINTED



COD. 14 CROMO SATINATO  
SATIN CHROME

COD. 37 OTTONATO LUCIDO  
BRASS PLATED

COD. 49 BIANCO VERNICIATO  
WHITE PAINTED

COD. 39 CROMO LUCIDO  
POLISHED CHROME

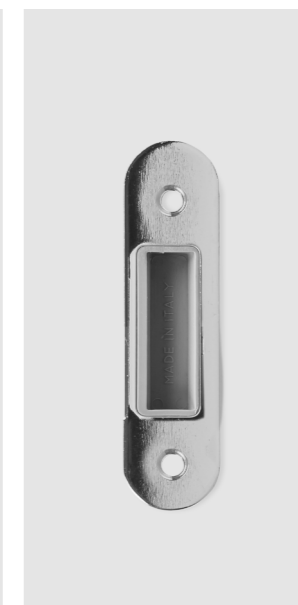

D

DUMMY

# DUMMY

COD. 128032

DUMMY È UN SISTEMA BREVETTATO CHE GRAZIE AD UN CILINDRO PERMETTE IL FISSAGGIO SUL PANNELLO PORTA DI UNA MANIGLIA NUDA O QUALSIASI ALTRA MANIGLIA IN ASSENZA DI UNA SERRATURA. DUMMY È SVILUPPATO PER PORTE, PANNELLI DI BOISERIE, ANTE DI MOBILI O CABINE ARMADIO DOVE NON È RICHIESTA UNA FUNZIONE DI CHIUSURA MA ESCLUSIVAMENTE UNA MANIGLIA PER POTER SPINGERE E TIRARE L'ANTA. DUMMY PERMETTE IL FISSAGGIO DELLA MANIGLIA SU ENTRAMBI I LATI O SU UN UNICO LATO DEL PANNELLO PORTA. DISPONIBILE PER TUTTI I MODELLI DELLA COLLEZIONE NUDA.

DUMMY THROUGH A CYLINDER, ALLOWS THE FIXING OF A NUDA HANDLE OR ANY OTHER TYPE OF HANDLE ON A DOOR PANEL WITHOUT ANY LOCKING SYSTEM. DUMMY IS A PATENTED PRODUCT DEVELOPED FOR DOORS, BOISERIE PANELS, WALK IN CABINETS WHERE NO LOCKING IS NEEDED BUT JUST PULLING AND PUSHING FUNCTION IS REQUIRED. IT KEEPS THE HANDLE FIXED TO THE PANEL. DUMMY IS SUITABLE FOR FIXING A HANDLE ON BOTH SIDES OR JUST ONE SIDE OF THE DOOR. AVAILABLE FOR ALL NUDA MODELS.



MM  
INCH

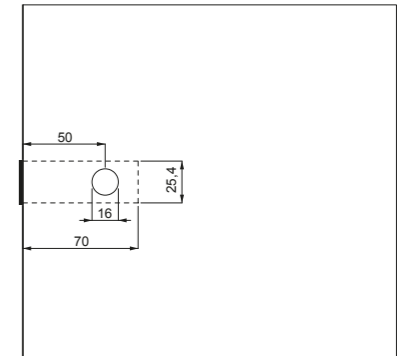
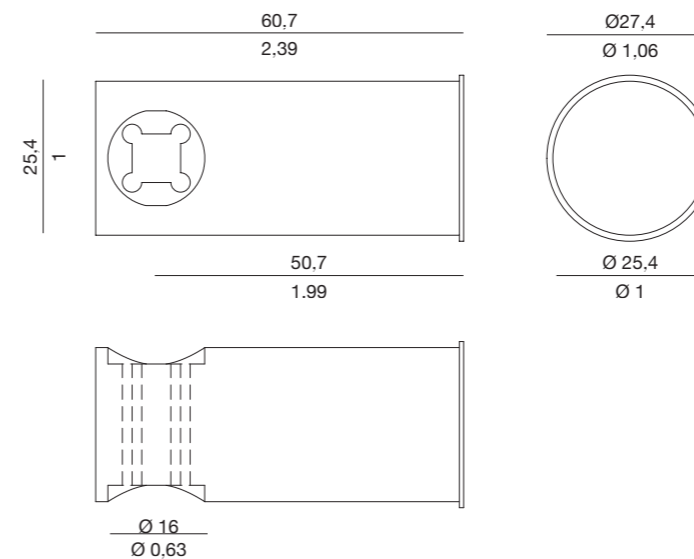

DUMMY MANIGLIA DESTRA  
DUMMY RIGHT HANDLE

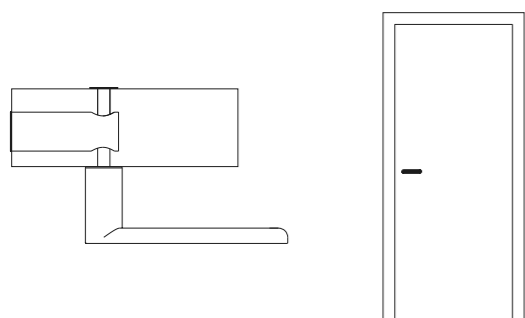

PURE	COD. 130401
WIND	COD. 130402
ATLANTA	COD. 130403
LIEVE	COD. 130405
BAAR	COD. 130406
PEPE	COD. 130407
7900	COD. 130411
OLEA	COD. 130414

DUMMY MANIGLIA SINISTRA  
DUMMY LEFT HANDLE

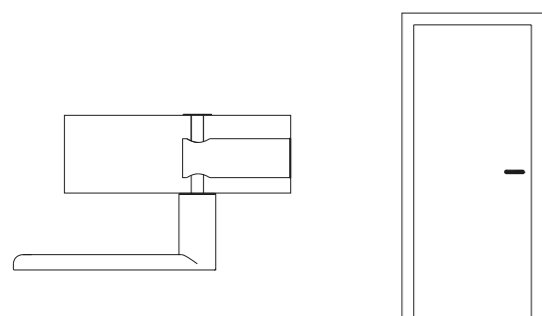

PURE	COD. 130501
WIND	COD. 130502
ATLANTA	COD. 130503
LIEVE	COD. 130505
BAAR	COD. 130506
PEPE	COD. 130507
7900	COD. 130511
OLEA	COD. 130514

DUMMY MANIGLIA DESTRA + MANIGLIA SINISTRA  
DUMMY RIGHT HANDLE + LEFT HANDLE

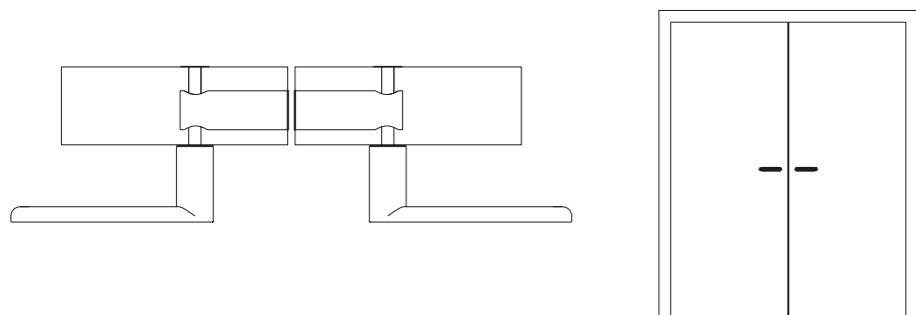

PURE	COD. 130601
WIND	COD. 130602
ATLANTA	COD. 130603
LIEVE	COD. 130605
BAAR	COD. 130606
PEPE	COD. 130607
7900	COD. 130611
OLEA	COD. 130614

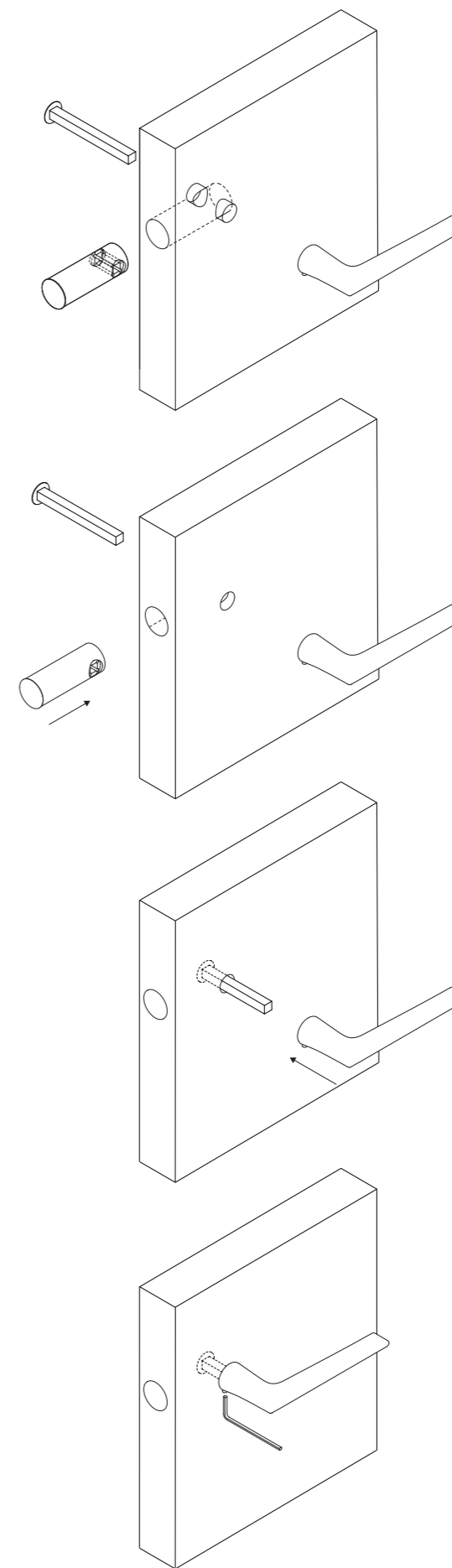

# DUMMY CLEVER

COD. 128032M

DUMMY CLEVER HA LA MEDESIMA FUNZIONALITÀ DI DUMMY, PERMETTENDO PERÒ DI TENERE LA PORTA IN POSIZIONE DI CHIUSURA GRAZIE ALL'ATTRAZIONE MAGNETICA.  
 IL PLUS DI QUESTO SISTEMA BREVETTATO CONSISTE NELL'APPLICAZIONE DI UN MAGNETE ALL'INTERNO DEL CORPO CILINDRICO CHE VIENE ATTRATTO DA UN SECONDO MAGNETE MONTATO NELLO STIPITE; IN QUESTO MODO È POSSIBILE TENERE LA PORTA IN POSIZIONE DI CHIUSURA.  
 DUMMY CLEVER PERMETTE IL FISSAGGIO DELLA MANIGLIA SU UN SOLO LATO DELLA PORTA O SU ENTRAMBI.  
 DISPONIBILE PER TUTTI I MODELLI DELLA COLLEZIONE NUDA.

DUMMY CLEVER HAS THE SAME FUNCTION OF DUMMY BUT IT CAN ALSO KEEP THE DOOR SHUT THANKS TO MAGNETIC ATTRACTION.  
 THE PLUS OF THIS PATENTED SYSTEM IS THE MAGNET IN THE CYLINDRICAL BODY WHICH IS ATTRACTED TO ANOTHER MAGNET TO BE FIXED IN THE DOOR FRAME; IN THIS WAY IT IS POSSIBLE TO KEEP THE DOOR SHUT.  
 DUMMY CLEVER IS SUITABLE FOR FIXING A HANDLE ON BOTH SIDES OR JUST ONE SIDE OF THE DOOR.  
 AVAILABLE FOR ALL NUDA MODELS.

STIPITE /  
FRAME

PORTA /  
DOOR

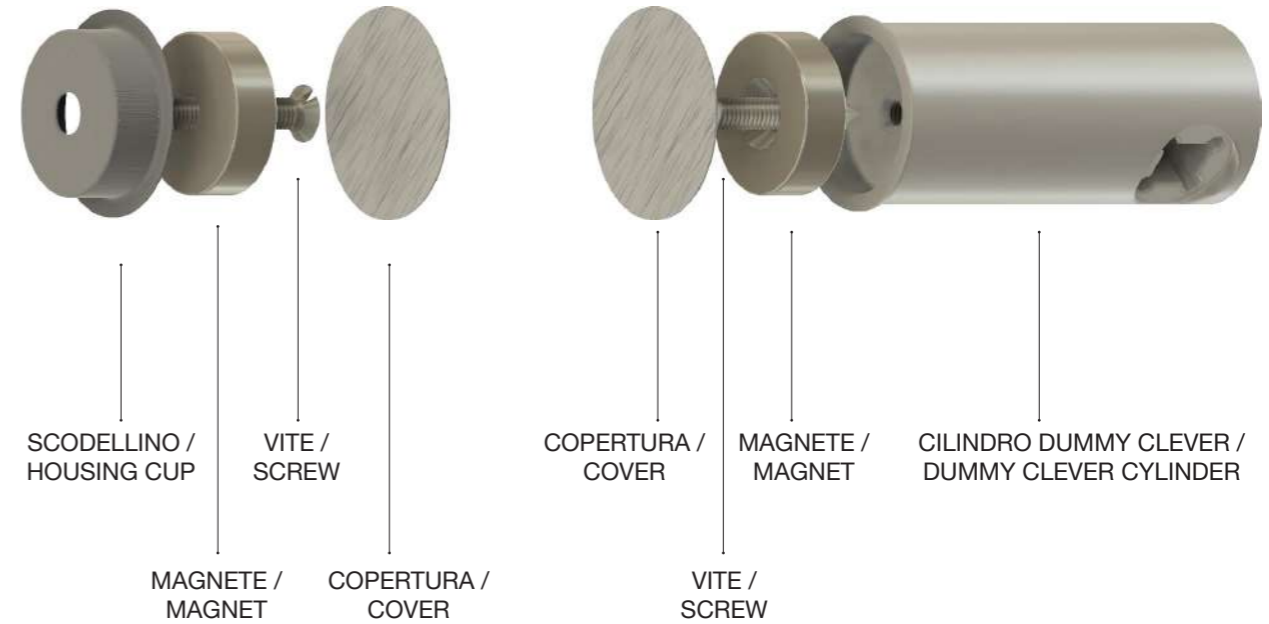

MM  
INCH

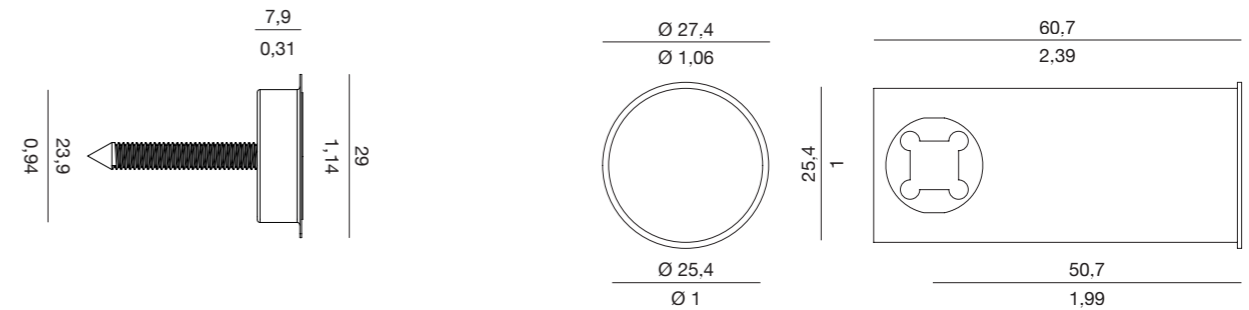

DUMMY CLEVER MANIGLIA DESTRA  
DUMMY CLEVER RIGHT HANDLE

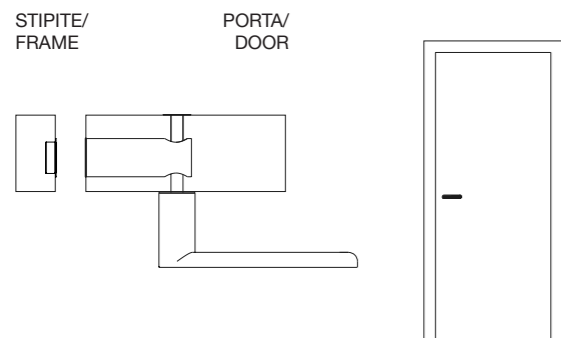

PURE	COD. 130401M
WIND	COD. 130402M
ATLANTA	COD. 130403M
LIEVE	COD. 130405M
BAAR	COD. 130406M
PEPE	COD. 130407M
7900	COD. 130411M
OLEA	COD. 130414M

DUMMY CLEVER MANIGLIA SINISTRA  
DUMMY CLEVER LEFT HANDLE

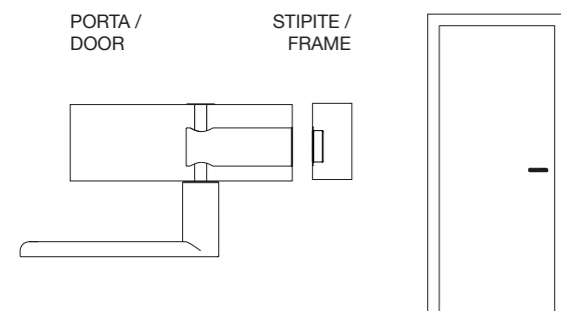

PURE	COD. 130501M
WIND	COD. 130502M
ATLANTA	COD. 130503M
LIEVE	COD. 130505M
BAAR	COD. 130506M
PEPE	COD. 130507M
7900	COD. 130511M
OLEA	COD. 130514M

DUMMY CLEVER MANIGLIA DESTRA + SINISTRA  
DUMMY CLEVER RIGHT HANDLE + LEFT HANDLE

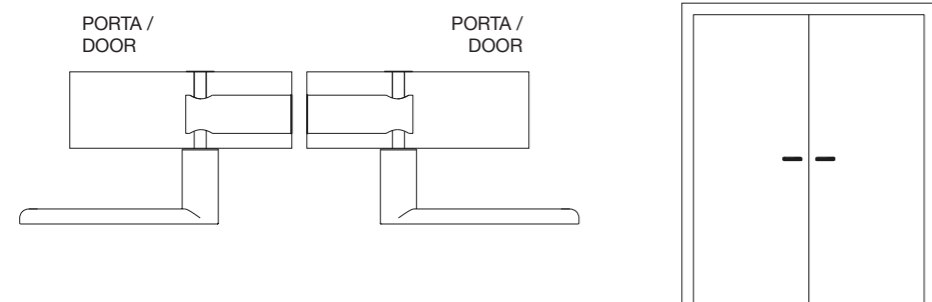

PURE	COD. 130601M
WIND	COD. 130602M
ATLANTA	COD. 130603M
LIEVE	COD. 130605M
BAAR	COD. 130606M
PEPE	COD. 130607M
7900	COD. 130611M
OLEA	COD. 130614M

